

## Gleitlager Type TGL

NW 15 - 200

h = 100

Jede andere Bauhöhe sowie ein Neigen der Rohrschellenachse ist möglich.

Tatsächliche Abmessungen der Rohrbefestigungen hängen von den einzelnen Profiltoleranzen ab.  
Berechnungsgrundlagen der Belastungswerte siehe Seite 2.0 und 2.1. Die angegebenen Belastungswerte sind für Material S235JR bei Raumtemperatur angegeben.

Technische Änderungen vorbehalten.

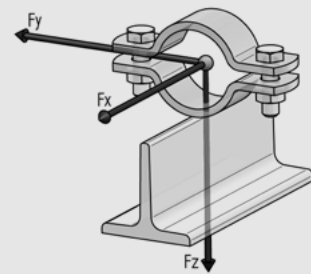
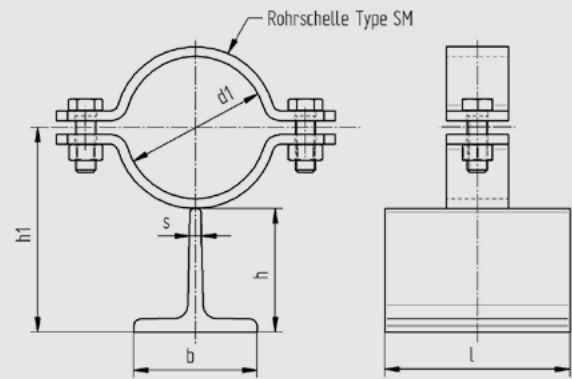

d1	Nennweite	Profil bxhxs	h	h1	l	Gewicht kg/Stk.	Fz (kN)
22	15	100x100x11	100	116	150	2,76	3,8
27	20	100x100x11	100	118	150	2,76	3,8
34	25	100x100x11	100	122	150	2,80	3,8
43	32	100x100x11	100	126	150	2,82	3,8
49	40	100x100x11	100	129	150	2,84	3,8
53	50	100x100x11	100	132	150	3,15	6,4
61	50	100x100x11	100	136	150	3,19	6,4
68	65	100x100x11	100	140	150	3,22	6,4
77	65	100x100x11	100	144	150	3,28	6,4
83	80	100x100x11	100	147	150	3,32	6,4
89	80	100x100x11	100	150	150	3,35	6,4
104	100	100x100x11	100	160	150	4,31	9,6
108	100	100x100x11	100	162	150	4,35	9,6
115	100	100x100x11	100	165	150	4,41	9,6
129	125	100x100x11	100	172	150	4,54	9,6
133	125	100x100x11	100	174	150	4,57	9,6
140	125	100x100x11	100	178	150	4,66	9,6
154	150	100x100x11	100	185	150	4,81	9,6
159	150	100x100x11	100	187	150	4,84	9,6
169	150	100x100x11	100	192	150	4,94	9,6
191	175	100x100x11	100	203	150	5,15	9,6
204	200	100x100x11	100	210	150	5,29	9,6
220	200	100x100x11	100	218	150	5,45	9,6